

Designed to cut extra-wide keyways, stress relief pockets, motor mounts slots, and more.

A compact, rugged, portable milling machine, the fully CE-Compliant KM4000 Portable Key Mill is designed to cut extra-wide keyways, stress relief pockets, motor mount slots, and more.

High quality, heavy-duty machine

- Cuts new keyways up to 3.25 inches (82.6 mm) wide and 7.88 inches (200.2 mm) long in one setup.
- Two-inch (50.8 mm) lateral travel allows cutting wide pockets or slots with a single end mill.
- Universal type motor and triple gear reduction provide plenty of torque.
- Permanently sealed lubrication, so machine can be operated at any angle.
- The leadscrew is a precision Acme thread and is fitted with roller thrust bearings.
- Anti-friction bearings used throughout.
- Dovetail ways machined for smooth movement in both longitudinal and transversal directions.
- Features zeroing-type adjusting dial for controlling cutter depth.
- Contoured base is self-centering and self-aligning on the shaft.
- Electronic speed control offers precision control of spindle speeds while retaining full torque over available rpm range.

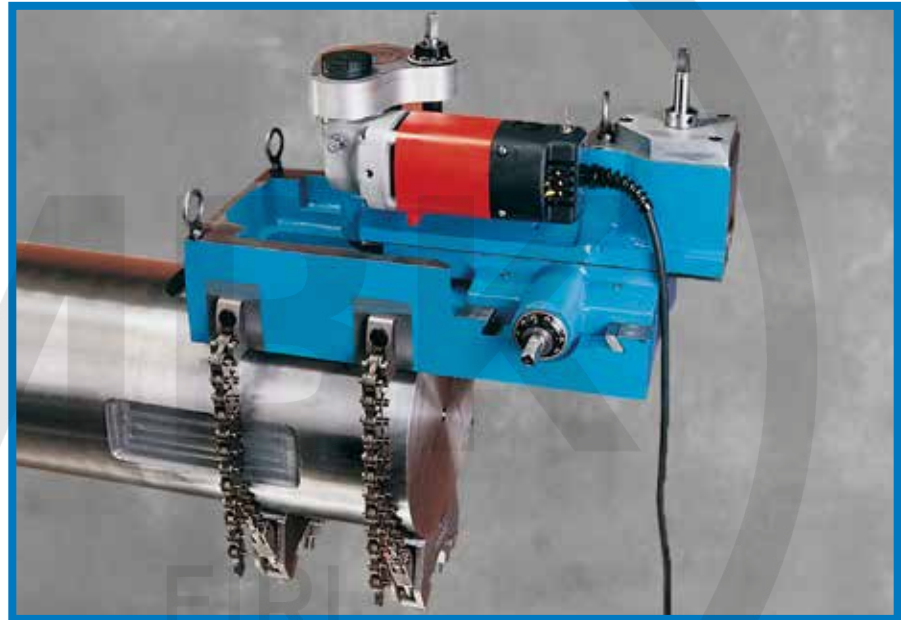

Compact, easy to set up, versatile

- Needs only 8.5 inches (215.9 mm) of shaft for clamping, or only 10.5 inches (266.7 mm) of shaft for clamping from an obstruction.
- Mounts on shafts from 4 - 24 inches (101.6 - 609.6 mm) in diameter.
- Mounts anywhere along the shaft.
- Rapid longitudinal travel can be made with a drill motor for quick setups.

Technical Data

- 0.75 inches (19.05 mm) is the standard spindle size for inch-machines
- 20 mm (0.79 inches) is the standard spindle size for metric machines.
- Many different machine variations are possible, contact your Climax Sales Representative for more information.

447-3377

oficina@vendo.com.pe

SPECIFICATIONS

		US	Metric
Overall length		18.5 inches	469.9 mm
Overall width		14.0 inches	355.6 mm
Overall height		13.25 inches	336.6 mm
Base size		9.0 x 18.5 inches	228.6 x 469.9 mm
Slide travel, longitudinal		7.88 inches	200.2 mm
Slide travel, transversal		2.0 inches	50.8 mm
Vertical travel max		3.0 inches	76.2 mm
Power, electric: 120V or 230V, 50-60Hz		1.0 Hp	0.75 kW
Power, pneumatic		1.2 Hp	0.9 kW
Power, hydraulic		4.0 Hp	2.98 kW
No load variable spindle speed			
minimum		350 rpm	350 rpm
maximum		675 rpm	675 rpm
Spindle hole diameter	INCH METRIC	0.75 inches 0.79 inches	19.1 mm 20 mm
Maximum end mill diameter		1.25 inches	31.75 mm
Maximum shaft diameter:			
standard bar clamp		18.0 inches	457.2 mm
with optional chain clamp		24.0 inches	609.6 mm
Minimum shaft diameter:			
standard bar clamp		8.0 inches	203.2 mm
with optional shim kit		4.0 inches	101.6 mm
Minimum clamping space required			
	on stub shaft	8.0 inches	203.2 mm
	obstructed shaft	10.5 inches	266.7 mm
		(NOTE: The KM4000 can cut keyways within 2.2 inches (55.88 mm) of the obstruction)	
One end mill included		Ø 0.75 inches	Ø 19.1 mm
Operating weight		195 lbs.	89 kg
Shipping weight (with speed control)		250 lbs.	114 kg
Shipping dimensions		24 x 24 x 19 inches	610 x 610 x 483 mm
Machining Ability Example			
Material		C1018 steel	C1018 steel
Metal removal rate		1 inch ³ /minute	16.4 cm ³ /min
Keyway dimensions		1.0 x 0.5 x 8.0 inches	25.4 mm x 12.7 mm x 203.2 mm
Cutting Time		3 minutes and 10 seconds	3 minutes and 10 seconds

All dimensions should be considered reference. Contact your Climax Representative for precision dimensions. Specifications are subject to change without notice. There are no systems or components on this machine that are capable of producing hazardous EMC, UV or other radiation hazards. The machine does not use lasers nor does it create hazardous materials such as gasses or dust.

DIMENSIONS, SETUP & OPERATION

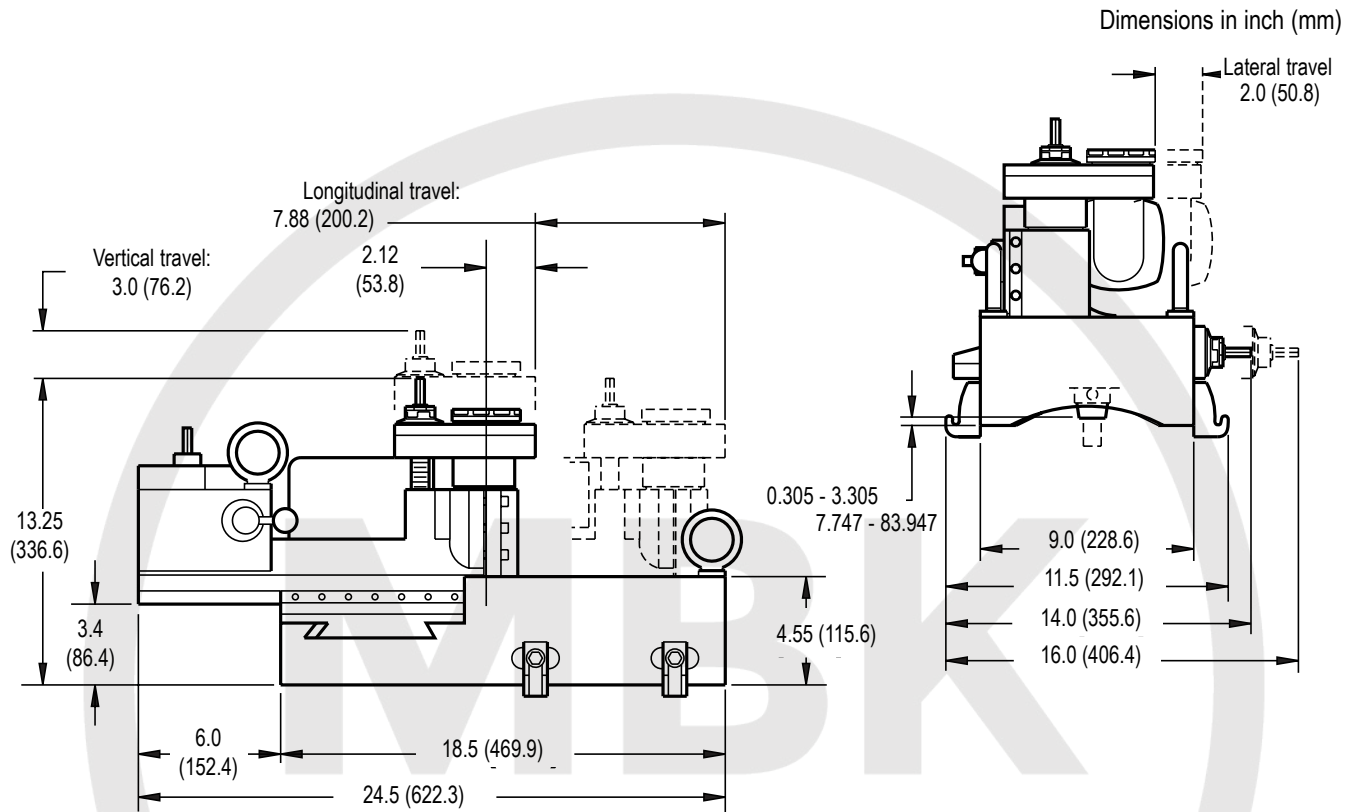

Set-up and Operation

Insert the end mill in the spindle of the KM4000 Portable Key Mill, and clamp it on that shaft - it's that simple. On a straight shaft, an experienced operator can mount the machine and be ready to cut a new keyway in less than 15 minutes! Shimming to tapered shafts may take a little longer.

The 2.0 inch (50.8 mm) lateral travel of the KM4000 allows you to cut wide keyways or slots with a less expensive, smaller end mill. The calibrated cross slide is positioned with the hand crank.

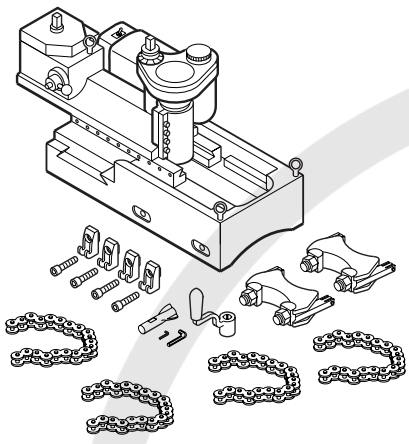
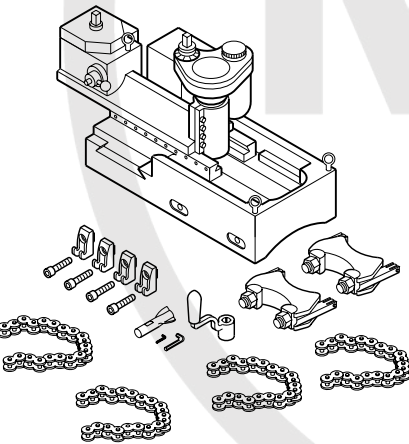
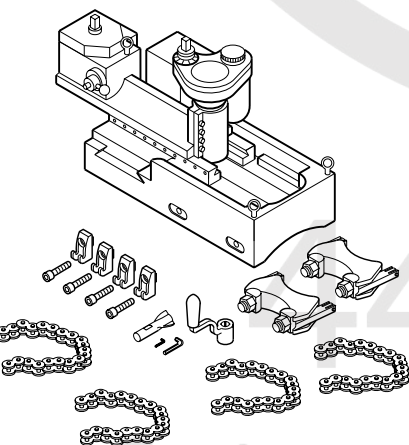

TOOL CONFIGURATIONS

	No. Description
	<p>KM4000 Portable Key Mill, Electric, all CE-Compliant Standard key mill Model KM4000 complete with 1.0 Hp (0.75 kW) electric motor, chain clamp, end mill, hex wrenches, crank, speed control, and instruction manual. Shipped in wooden crate.</p> <p>10505 KM4000, inch 120V Inch, 120V motor. 3/4-inch spindle Approx. net weight 240 lb (110 kg).</p> <p>10508 KM4000, metric 120V Metric. 120V motor. 20 mm spindle Approx. net weight 240 lb (110 kg).</p> <p>10506 KM4000, inch 230V Inch, 230V input /120V output motor. 3/4-inch spindle Approx. net weight 240 lb (110 kg).</p> <p>10509 KM4000, metric 230V Metric, 230V input / 120V output motor. 20 mm spindle Approx. net weight 240 lb (110 kg).</p>
	<p>KM4000 Portable Key Mill, Pneumatic, all CE-Compliant Standard Key Mill Model KM4000 complete with 1.2 hp (0.9 kW) pneumatic motor*, chain clamp, end mill, hex wrenches, crank, and instruction manual. Shipped in wooden crate.</p> <p>10507 KM4000 - inch As above with 3/4-inch spindle. Approx. net weight 245 lb (112 kg)</p> <p>10510 KM4000 - metric As above with 20 mm spindle Approx. net weight 245 lb (112 kg)</p> <p>* Motor requires 40 ft³/min (1 m³/min) at 90 psi (620 kPa).</p>
 <p data-bbox="162 1827 649 1890">NOTE: Drawings are for reference only, are not to scale, and may not represent actual product.</p>	<p>KM4000 Portable Key Mill, Hydraulic, all CE-Compliant Standard Key Mill Model KM4000 complete with 4.0 Hp (2.98 kW) hydraulic motor, chain clamp, end mill, hex wrenches, crank, and instruction manual. Shipped in wooden crate.</p> <p>16297 KM4000 - hydraulic 274 rpm 3/4-inch spindle. Hydraulic motor delivers approx. 274 rpm at the spindle @ 6 gal/min (22.3 liter/min). Approx. net weight 233 lb (106 kg).</p> <p>16314 KM4000 - hydraulic 430 rpm 3/4-inch spindle. Hydraulic motor delivers approx. 430 rpm at the spindle @ 6 gal/min (22.3 liter/min). Approx. net weight 233 lb (106 kg).</p> <p>16315 KM4000 - hydraulic 664 rpm 3/4-inch spindle. Hydraulic motor delivers approx. 664 rpm at the spindle @ 6 gal/min (22.3 liter/min). Approx. net weight 233 lb (106 kg).</p>

TOOL CONFIGURATIONS

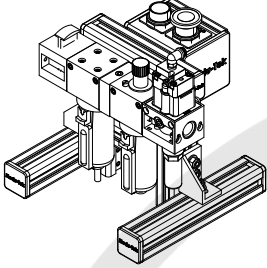
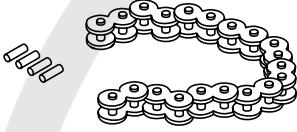
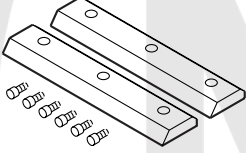
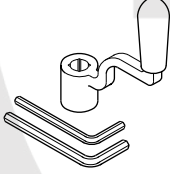
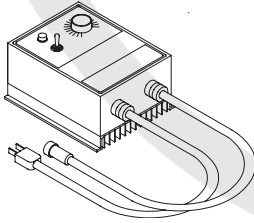
	No. Description
	<p>59246 Pneumatic conditioning unit Required to protect air motor warranty. Includes: lubricator, filter, stand, and air line. Sold only as a unit. Approx. net weight 11 lbs (5 kg).</p>
	<p>10493 Chain clamp assembly 20 inch (508 mm) chains for use in addition to standard chain clamp assembly. Used to attach key mill to shafts 18 - 24 inches (457.2 - 609.6 mm) in diameter. Approx. net weight 8.6 lbs (3.9 kg).</p>
	<p>11851 Shim kit Shims fit inside base to enable the key mill to be mounted on shafts as small as 4.0 inches (101.6 mm) in diameter. Approx. net weight: 3.4 lbs (1.6 kg).</p>
	<p>13737 Tool kit Hand crank and hex wrenches necessary to operate the key mill. Approx. net weight 0.5 lbs (0.3 kg)</p>
	<p>36549 Speed Control Assembly 120V Provides on/off and variable speed of the motor. Fits current generation of KM motors only, not older models. Standard NEMA 5-15 straight blade plug with ground.</p> <p>36685 Speed Control Assembly 230V, CE-Compliant Provides on/off and variable speed of the motor. Fits current generation of KM motors only, not older models. European Schuko style plug.</p> <p>36950 Speed Control Assembly and Retrofit Kit Provides on/off and variable speed of the motor. Includes Part Number 36549 Speed Control Assembly with the new end cap assembly (Part Number 34142) for the motor to retrofit older machines to the current controller. Standard NEMA 5-15 straight blade plug with ground.</p>

NOTE: Drawings are for reference only, are not to scale, and may not represent actual product.

The KM4000 is widely used by these industries:

- Construction
- Bridge building & repair
- Power Generation
- Ship building
- Pulp and paper
- Steel and aluminum

Typical applications:

- Keyways on tapered shafts
- Milling stress relief pockets on bridge decks
- Cut motor mount slots in plate or I-beams
- Cut inspection windows in vessels
- Cut keyways on motors

Mounting applications include:**Mounting on end of shaft**

Needs only 8.5 inches (215.9 mm) of shaft for clamping, or only 10.5 inches (266.7 mm) of shaft for clamping from an obstruction. (NOTE: The KM4000 can cut keyways within 2.2 inches (55.88 mm) of the obstruction)

Mount in the middle

The machine can be leveled for cutting long keyways.

Tapered shafts

Mounting on tapered shafts requires shimming

447-3377

oficina@vendo.com.pe

Training at the Global Learning Center

Climax has been teaching the fundamentals and fine points of portable machine tool operation for practically as long as we've been inventing and building the tools.

At the Climax Global Learning Center situated in our corporate headquarters near Portland, Oregon, we provide training for machine tool operators on portable machine tool safety, and machine setup and operation. Trainees also receive technical tips and tools to improve operational efficiencies, with the vast majority of every program devoted to hands-on activities and skill development.



The Climax instructional team includes specialists in shipbuilding, power generation, civil engineering, bridge re-building, petrochemical and other industries.

Whether it's a regularly scheduled course at the Global Learning Center, or custom curriculum conducted at your facility, your machinists will benefit from courses developed by some of the most respected authorities in the business.

Call us today to register for a regularly scheduled class, or talk to us about how we can customize a training program for your specialized application.



CLIMAX GLOBAL LOCATIONS

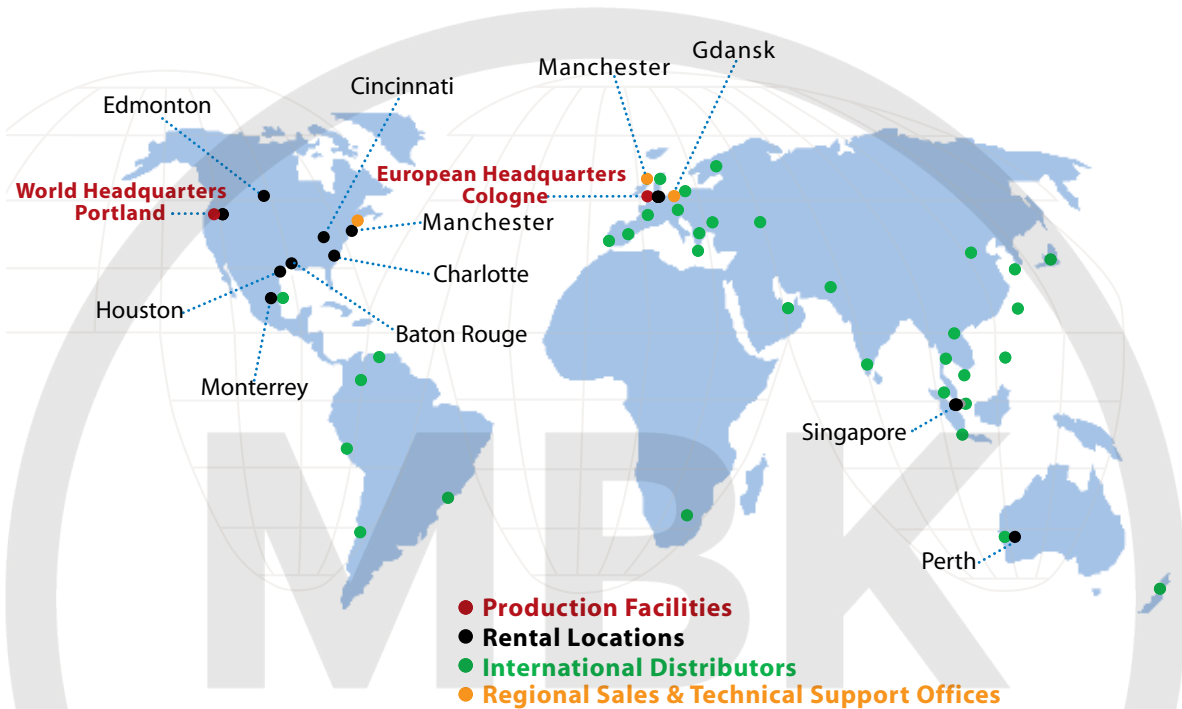

Call Climax for:

On-site Training

Need some refresher courses in setting up and operating your Climax machine tool?

Special Projects

Climax has been solving complicated on-site machining and welding problems for our customers since 1964.

Rentals

With 16 worldwide rental depot locations, you are never far away from a Climax portable machine tool.

Connect with us:    

World Headquarters

2712 E. Second Street
Newberg, Oregon 97132 USA
Worldwide Telephone: 1.503.538.2185
N. America Toll-Free: 1.800.333.8311
Fax: 1.503.538.7600
Email: info@cpmt.com

European Headquarters

Am Langen Graben 8
52353 Düren, Germany
Telephone: (+49) (0) 2421.9177.0
Fax: (+49) (0) 2421.9177.29
Email: info@cpmt.de