

# *Climax Valve Repair Machines*

**VM7000**  
**VM6000**  
**VM8000**

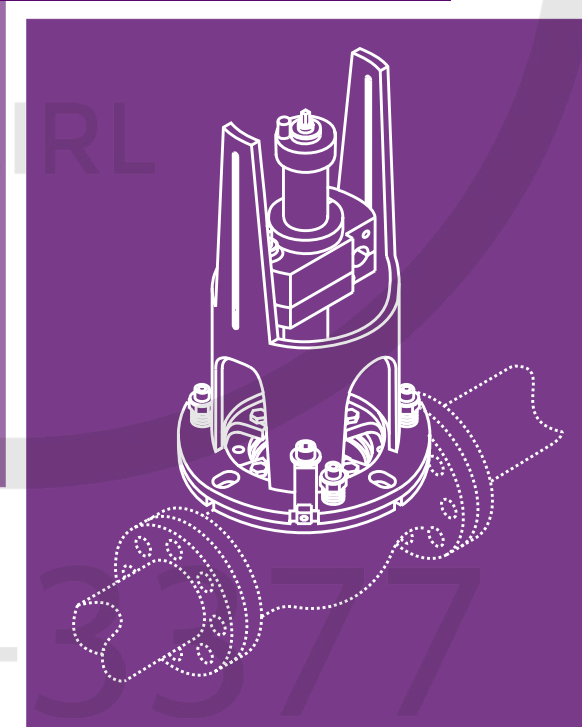
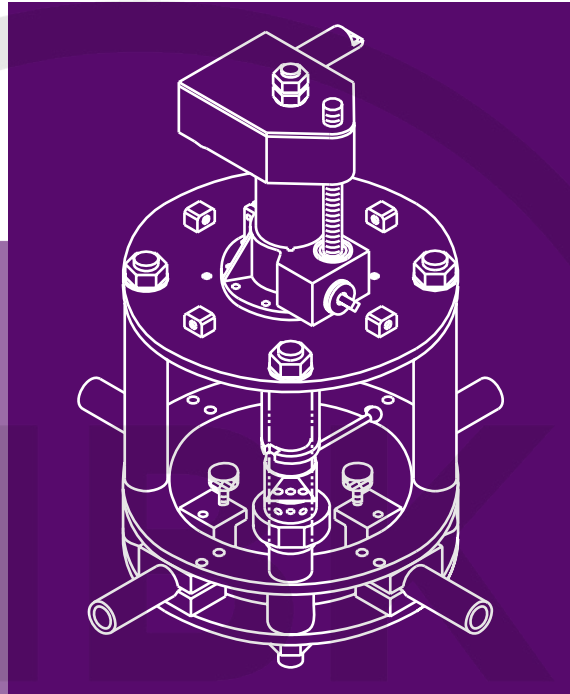
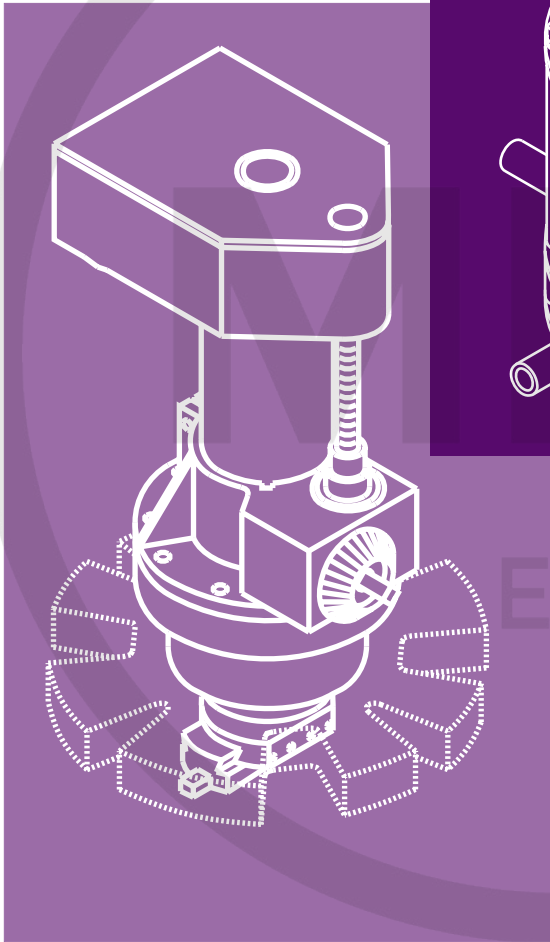

**descriptions • specifications • operational dimensions • components**

[oficina@vendo.com.pe](mailto:oficina@vendo.com.pe)



**CLIMAX**  
Portable Machine Tools, Inc.

# Model VM7000 Valve Boring Machine

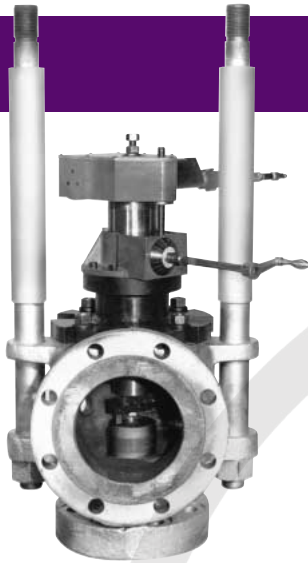

**Now you can repair a safety valve in about the same time it would take to remove the damaged valve.**

If the valve was welded in-line, eliminate rewelding and

recertification by remachining in place. By eliminating downtime and spare valve inventory costs, you can probably pay for the Model VM7000 by repairing just a few valves in-line.

## Capabilities

The Model VM7000 is designed to mount directly on safety valves and rework nozzles up to 4" (101.6mm) in diameter. The VM7000 will mount on Dresser Consolidated Maxi-Flow valves, orifice sizes 1 through 6, and on many Crosby Safety Valves.

Any safety valve with a similar configuration can be repaired with the VM7000 (optional modified

mounting fixtures may be needed). Combine the various tool bits and tool holders to remachine valve bushing seats to the manufacturer's original specifications. Machine outside diameter, inside diameter, and bushing seat faces to close tolerances.

## Features

The VM7000 consists of a compact pneumatic power head and spindle, a set of mounting fixtures, and tool heads for a range of machining operations.

The power head features a 1.2 hp (.90 kW) pneumatic motor that drives a worm gear reduction, for plenty of torque at the tool head. The spindle turns in ball bearings to ensure smooth operation.

The tooling assembly consists of the tool head, the tool set fixture, the boring and facing heads, and the tool bits. A draw bolt holds the tool head to the spindle. The tooling assembly does three basic valve remachining operations: boring, turning and facing.

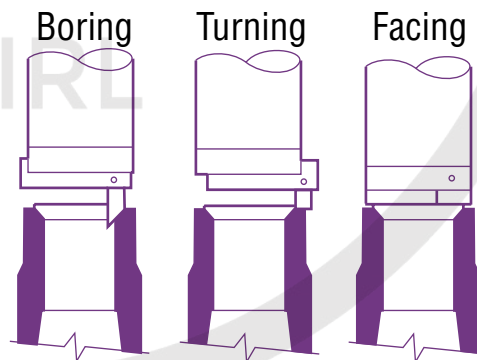

**Three tool configurations and machining operations for the VM7000**

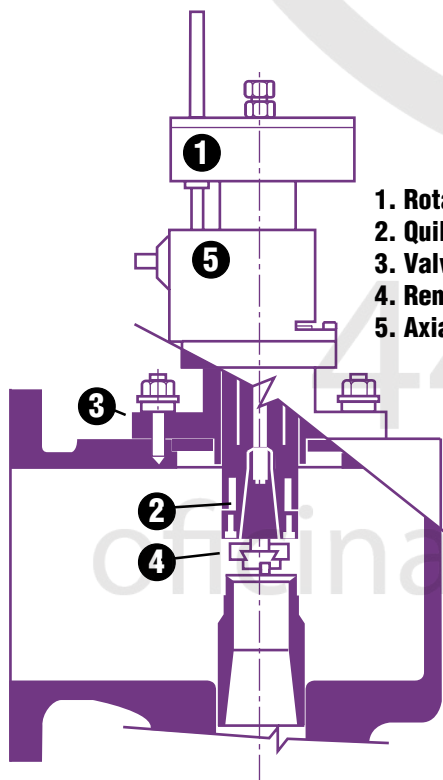

1. Rotational drive box
2. Quill
3. Valve mounting fixture
4. Removable tool head
5. Axial feed control

The VM7000 mounts on the valve with a fixturing assembly that consists of mounting fixtures, adapter rings and clamp bars. The adapter ring, machined to fit standard valve bore sizes, centers and aligns the machine in the valve opening. The adapter ring raises the machine slightly above the flange surface to ensure alignment with the valve axis, even if the valve face is uneven due to corrosion. The valve mounting fixture uses existing valve flange studs.

## Setup and Operation

To set up the VM7000, pick the proper adapter ring and put it in the valve's counterbore. The upper surface of the ring will be slightly above the surface of the valve face.

Next, choose the proper mounting fixture and put it on the valve. The adapter ring will automatically center the mounting fixture. Rotate the mounting fixture to fit the slots to the valve studs.

Once the mounting fixture is set up, the power head with attached tool head goes into the mounting fixture bore and is bolted in place. With the proper head and tool bit in place, you can do facing, boring and turning operations. Vertical feed is controlled manually. The vertical adjustment dial is calibrated in .001 inch increments.

To start a cut, turn the vertical feed crank

clockwise until the tool just begins to cut and the vertical adjusting dial is zeroed. Then cut to the valve manufacturer's specified depth. A tool set fixture is provided with the machine to give a reference point for determining the cut diameter.

## Optional tool gage set

To ensure a perfect tool setup, Climax offers gage block sets that allow exact tool positioning every time. The gage blocks are precision machined to match the manufacturer's original valve nozzle specifications.

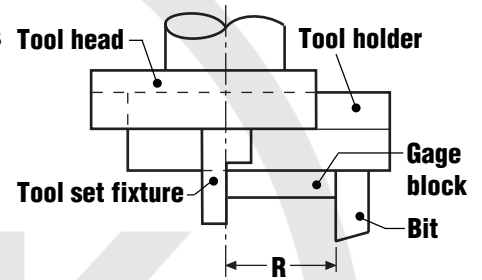

## Model 7000 Components

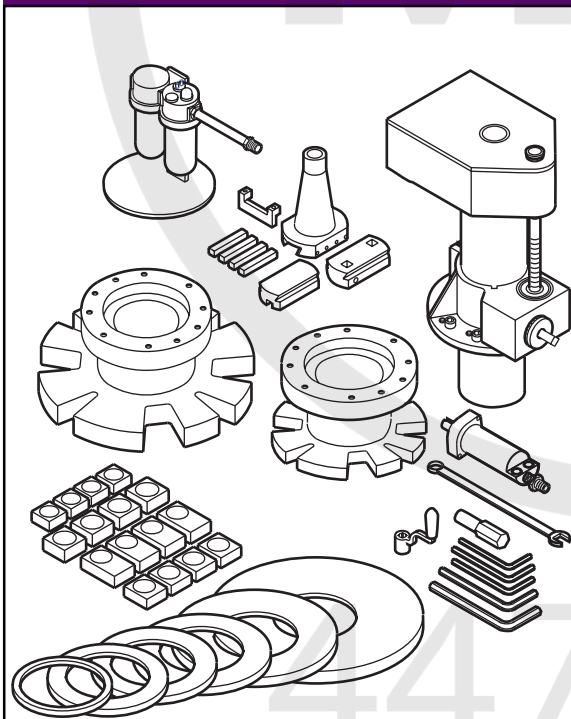

order no. description

### 16777 Model 7000 valve boring machine

Standard machine complete with mounting fixtures and adapter rings for mounting to the valve, 5" (127mm) stroke, 80 rpm power unit assembly, 1.2 hp (.90 kW) air motor, pneumatic conditioning unit, #40 taper spindle, tool heads, tool gage set, tool kit, instruction manual and wooden storage crate.

### 15220 Set tool gage set

Gage blocks precision machined to original specifications allow exact tool positioning. Contact your Climax representative for more information.

## VM7000 Specifications

## Operational Dimensions

	inch (mm)
<b>Valve nozzle dia. min.:</b>	1.5" (38 mm)
<b>Valve nozzle dia. max.:</b>	6" (152 mm)
<b>Air motor:</b>	1.2 hp (.90 kW)
<b>Stroke (slide travel) max.:</b>	5" (127 mm)
<b>Gear reduction:</b>	15:1
<b>Air pressure requirements:</b>	
(at rated hp)	90 psi @ 32 ft <sup>3</sup> /min. (6.2 bar @ 0.91 m <sup>3</sup> /min.)
(at max rpm)	90 psi @ 40 ft <sup>3</sup> /min. (6.2 bar @ 1.13 m <sup>3</sup> /min.)
<b>Max rpm:</b>	80 rpm
<b>Spindle rpm (at rated hp):</b>	54 rpm
<b>Spindle torque (at rated hp):</b>	90 ft-lbs (122.4N•m)
<b>Net weight:</b>	154 lbs (70 kg)
<b>Ship weight:</b>	176 lbs (80 kg)
<b>Axial feed:</b>	manual, adjustable in .001" (.025 mm) increments.

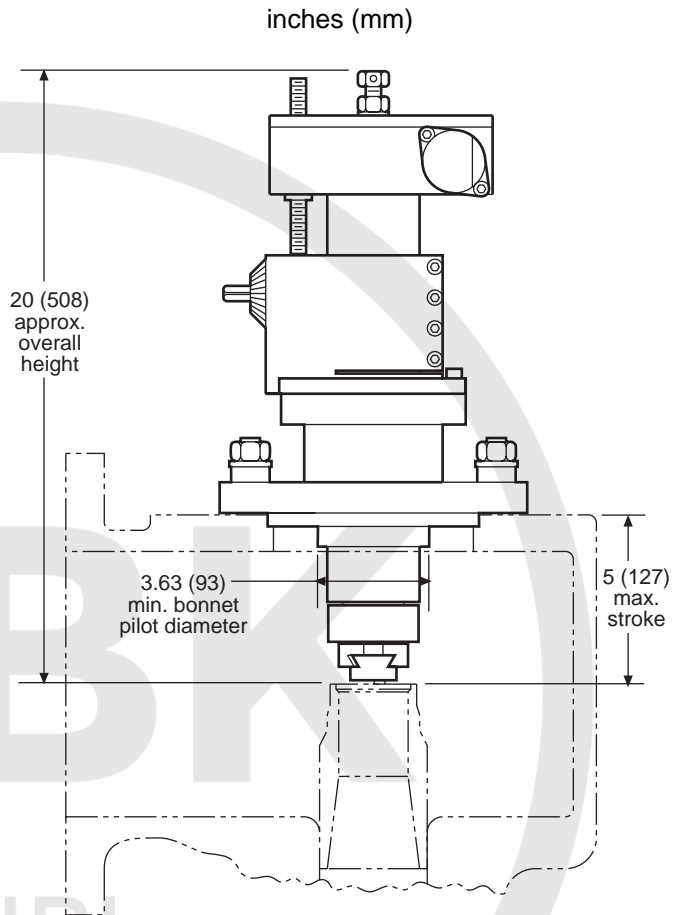

Note: fixtures will accommodate 4, 6, and 8-hole bolt patterns that are 5" to 10" (127 - 254mm) in diameter.

QUIK-TECH	VM7000	VM6000	VM8000	VM9000
Valve nozzle dia.	1.5-6 (38-152)	NA	NA	NA
Valve throat dia.	NA	2.5-13 (63-330)	3-10 (76-254)	16-28 (406-710)
Valve seat dia.	NA	2.5-13 (63-330)	2.5-10 (63-254)	16-28 (406-710)
Power	P	P	P, H	H

Power key: E = electric; P = pneumatic; H = hydraulic



# Model VM6000 Valve Boring Machine

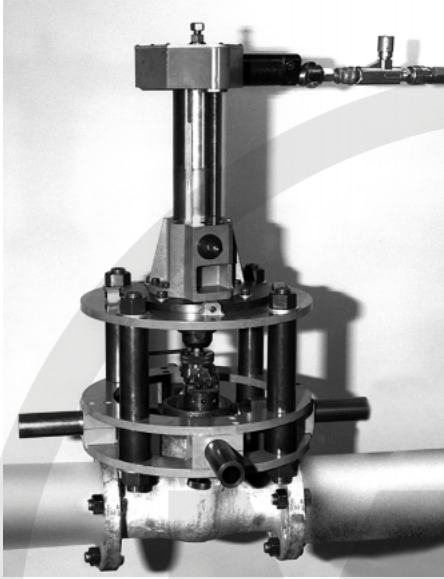

## Repair In-Line Valves With 2-1/2" to 13" Diameter Pressure Seal Bores

Valves are often damaged in the throat area by corrosion or steam cavitation. Now you can eliminate remove/replace downtime and expense by repairing the worn valve while you leave it in-line.

The Model VM6000 Portable Valve Repair Machine makes on-site repair of a wide range of valves practical. With the VM6000, you remove the valve bonnet assembly to allow access to the valve throat, machine a weld prep groove, apply a stainless weld buildup in the eroded area, and bore out the valve throat to original dimensions.

## Capabilities

The Model VM6000 is a "generic" valve repair machine that mounts on and bores the throat area of any valve the mounting fixtures can attach to. Using three mounting ring sizes, the VM6000 mounts directly on valves with outside flange diameters from 3.5" to 17" (88.9-431.8mm). It machines inside diameters from 2.5" to 13" (63.5-330.2mm). The VM6000 is capable of boring inside diameters, turning outside diameters, undercutting, and cutting recesses and grooves.

## Features

The VM6000's power head long ago proved its rugged dependability in our Model FF1000 portable flange facing machine. The 1.2 hp (.90 kW) pneumatic motor and gear reduction provide plenty of torque for remachining valves.

The mounting fixtures, which form a sturdy base, mount directly on the valve to align and center the unit. Two different tool heads provide access to any inside and outside diameter within the standard 2.5" to 13" (63.5-330.2mm) range.

Axial feed is via automatic power feed (optional digital readout available). The power feed unit can be quickly removed if you want manual feed for tool positioning. Automatic radial feed is incorporated in both tool heads and allows cutting of recesses and grooves. The small tool head feeds the tool radially at .0025" or .005" (.0635-.1270mm) per revolution. Automatic tool stop allows cutting to a preset diameter.

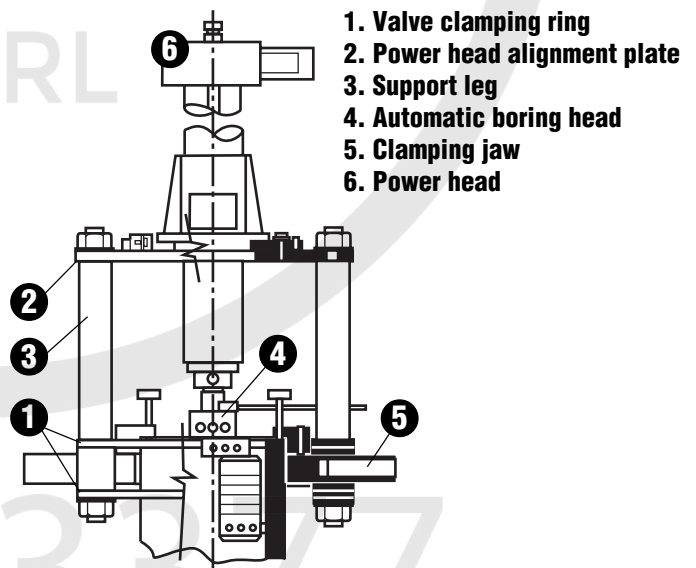

## Setup and Operation

To set up the VM6000, attach, center and align the proper mounting fixture components. Insert and center the power head/spindle and align it in the valve. Once the VM6000 has been aligned it can be removed and replaced without disturbing the alignment.

For cutting weld prep grooves, remove the machine from the mounting fixture and adjust the tool head using the bench gauge/fixture.

Once the cutting diameter and preset stop are set on the tool head, insert it in the power head spindle and replace the VM6000 in the valve. The machine is now ready to machine a weld prep groove to a preset depth. When boring, the radial feed is disengaged, the boring diameter is set using a micrometer and the boring depth is controlled manually. Depth of the bore is determined by visual inspection or optional digital readout.

After corroded material and old weldments are removed, take out the VM6000 and apply weld buildup as needed. Finally, reattach the VM6000 and remachine the valve to manufacturer's original specifications. There is one tool holder for each of the three standard machining operations.

### **Digital readout option**

A digital readout control unit is available for the Model VM6000 Valve Repair machine. This allows precise boring to a predetermined depth without visual inspection.

## **Model 6000 Components**

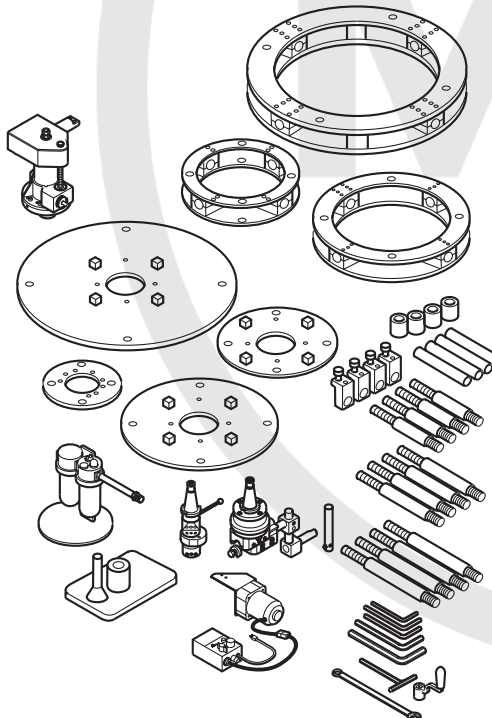
	order no. description
	<p><b>17151 Model 6000 valve boring machine</b> Standard machine complete with valve fixturing assembly for mounting to the valve, 8" stroke power unit assembly, 1.2 hp air motor, pneumatic conditioning unit, small and large tool holders, small (7"/177.8mm maximum OD valves), medium (10"/254mm maximum OD valves), and large (17"/431.8mm maximum OD valves) mounting rings, tool bits, tool fixture for presetting tool stops, electric power feed unit, tool kit, instruction manual, and wooden storage crate.</p> <p><b>30487 Digital readout option</b> Allows precise boring to a predetermined depth, without visual inspection.</p>

**Drawings may not represent actual product.**

447-3377

oficina@vendo.com.pe

## VM6000 Specifications

	<b>inch (mm)</b>
<b>Valve ID min.:</b>	2.5" (63.5 mm)
<b>Valve ID max.:</b>	13" (330 mm)
<b>Valve OD min.:</b>	3.5" (88.9 mm)
<b>Valve OD max.:</b>	17" (431.8 mm)
<b>Air motor:</b>	1.2 hp (.90 kW)
<b>Stroke (slide travel) max.:</b>	8" (203.2 mm)
<b>Air pressure requirements:</b>	
(at rated hp):	90 psi @ 40 ft <sup>3</sup> /min. 6.2 bar @ 1.13 m <sup>3</sup> /min.
(at max rpm):	90 psi @ 50 ft <sup>3</sup> /min. 6.2 bar @ 1.42 m <sup>3</sup> /min.
<b>Maximum rpm:</b>	80 rpm
<b>Spindle rpm (at rated hp):</b>	54 rpm
<b>Electric feed:</b>	115V
<b>Net weight:</b>	845 lbs (348 kg)
<b>Shipping weight:</b>	920 lbs (418 kg)
<b>Cutter:</b>	1/4" square HSS tool bit

**Radial feed (small tool holder):** automatic, .002" (.05 mm) per revolution.

**Radial feed (large tool holder):** automatic, .002, .004, .006, or .008" (.05, .10, .15, .20 mm) per revolution.

**Axial feed:** manual or automatic. Automatic feed is infinitely variable .04"-1.4" (1.0-35.5 mm) per minute.

## Operational Dimensions

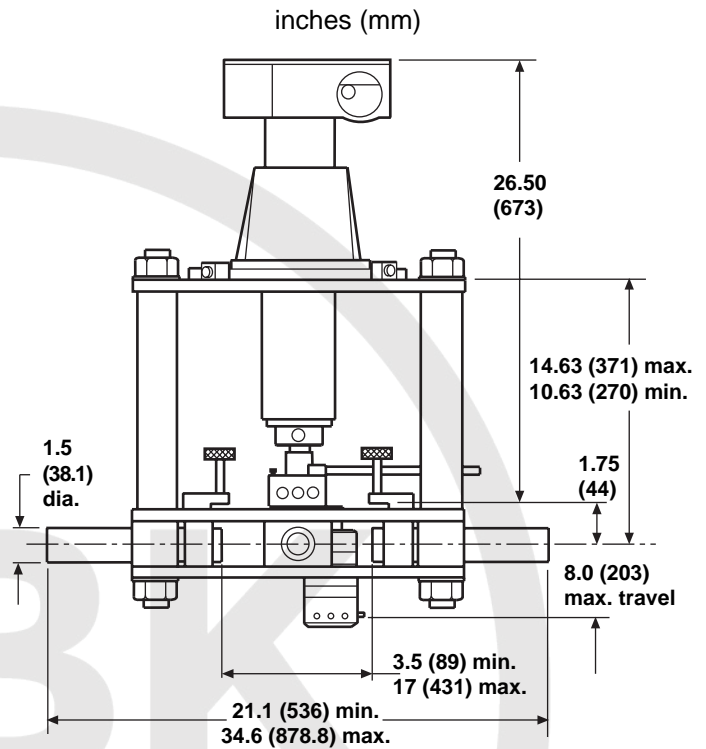

QUIK-TECH	VM7000	VM6000	VM8000	VM9000
Valve nozzle dia.	1.5-6 (38-152)	NA	NA	NA
Valve throat dia.	NA	2.5-13 (63-330)	3-10 (76-254)	16-28 (406-710)
Valve seat dia.	NA	2.5-13 (63-330)	2.5-10 (63-254)	16-28 (406-710)
Power	P	P	P, H	H

Power key: E = electric; P = pneumatic; H = hydraulic inches (mm)

oficina@vendo.com.pe

# Model VM8000 Valve Boring Machine



## **Repair corroded seal areas on-site with the valve in- line.**

Sometimes it's economical to replace smaller valves, but it's usually more cost-effective to

repair the larger sizes. Maintaining an inventory of replacement valves to keep your system operating would be prohibitive. Using portable machine tools to repair valves in-line, you save all the expense of replacement valve inventory, weld reinspection, recertification, and the downtime necessary to complete the job.

With the Model VM8000 Valve Repair machine, the repair operation consists of removing the valve bonnet and stem assembly, applying a stainless weld buildup in the valve seat and seal areas and remachining to the manufacturer's original specifications. The original in-line welds are not disturbed and need no recertification.

## **Capabilities**

The VM8000 is designed for on-site remachining of seats and seal areas of Fisher and Dresser

Masoneilan (or any other, similar type) control valves. The machine mounts directly on the valve and bores throat areas from 2.5" to 10" (63.5-254mm) in diameter. Also reface seats up to .75" (19.05mm) wide without tool bit adjustment. The machine can reach 16" (406.4mm) from the top to the valve body and has a boring stroke of 10" (254mm).

The machine cuts nearly any kind of finish from fine to 40-pitch scroll for gasket seals.

## **Features**

Components of the VM8000 include a main body, rotational drive unit, turning bar, mounting fixtures and tool holder set. Machining torque is delivered through the rotational drive unit, which may be either hydraulically or pneumatically driven. The axial feed system is manually controlled. Calibrated in .001" (.0254mm) increments, the feed dial can be zeroed to cut precise depths specified by the manufacturer. Boring diameter is set with the manual hand wheel on top of the bar. Make multiple boring passes without removing the machine for tool adjustments.

Pin locators in the mounting plates allow accurate repositioning of the machine's main body during multiple setups. Because the turning bar rotates in close-tolerance needle bearings, the machine is capable of high precision machining. During boring operations, total indicated runout (TIR) will not exceed .002" (.0508mm) over the entire stroke.

With the long turning bar, deep valve machining is possible. The rack-actuated tool head radial feed is automatic at .003" (.076mm) per revolution, or manual at .025" (.635mm) per revolution.

Precision machining is achieved with the calibrated radial feed dial located on top of the turning bar.

## **Setup and Operation**

Remove the valve's the bonnet and stem and mount the Model VM8000 base plate. Attach, center and level the intermediate plate and main body assembly. Cut the necessary weld preps, making sure old weldments and all corrosion is removed. Remove the VM6000 and apply weld buildup as needed. Using the pin locator system, the machine is reattached to the intermediate plate in perfect alignment for finish machining all seat and seal areas. The tool bit remains visible during machining operations so the operator has excellent control of all precision boring and facing operations.

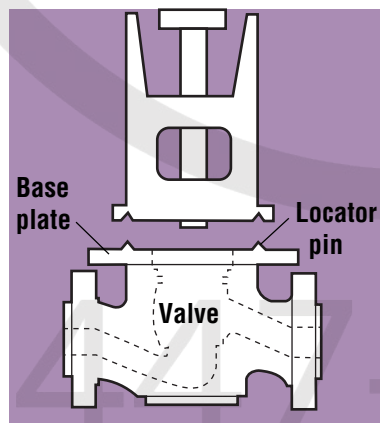



## Threading option

With the optional threading attachment, the machine can cut threads that meet the original manufacturer's specifications. The machine can cut any pitch between 8 and 16 threads per inch in 1/4-pitch increments and pitches 16 to 21 in 1-pitch increments. Any six pitches are provided with the machine. Thread pitch is changed by replacing the pitch gear in the optional threading attachment gear box... a five minute operation

## Model 8000 Components

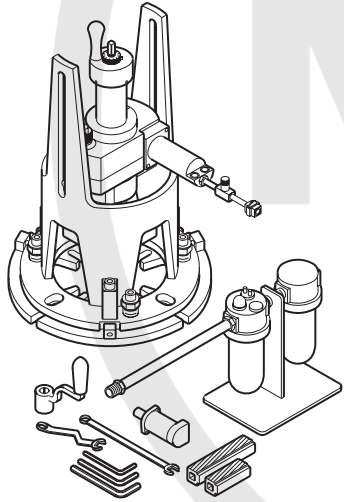
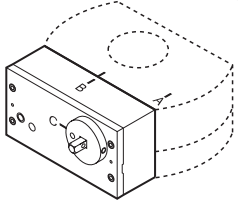
	order no. description
	<p><b>17794 Model 8000 valve repair machine</b> Standard machine includes rotational drive assembly with 1.1 hp air motor and 1.5 hp hydraulic motor, main body assembly with cone locators, turning bar assembly with three tool holders, pneumatic conditioning unit, tool kit, and instruction manual.</p> <p><b>17788 Model 8000 valve repair machine with threading attachment</b> As above with threading attachment described below.</p>
	<p><b>16208 Threading attachment</b> Threading attachment allows the Model VM8000 to cut new or recut existing threads in Fisher-style control valves. Cut from 8 to 20 threads/inch by changing the threading gears. Attachment includes gear box which mounts to the rotational drive assembly, threading gears for 8, 10, 12, 16, 18, and 20 threads/inch, slow speed 1.1 hp pneumatic motor (20 rpm max spindle speed), and instructions.</p>

**Drawings may not represent actual product.**

oficina@vendo.com.pe

## VM8000 Specifications

## Operational dimensions

	<b>inch (mm)</b>
<b>Height:</b>	39.0" (991 mm)
<b>Valve ID min.:</b>	3.0" (76.2 mm)
<b>Valve ID max.:</b>	10.0" (254 mm)
<b>Vertical stroke:</b>	
(slide travel) max.	10" (254 mm)
<b>Air motor:</b>	1.1 hp (0.83 kW)
<b>Air pressure requirements:</b>	
(at rated hp)	90 psi @ 32 ft <sup>3</sup> /min. (6.2 bar @ 1.1 m <sup>3</sup> /min.)
(at max rpm)	90 psi @ 40 ft <sup>3</sup> /min. (6.2 bar @ 1.13m <sup>3</sup> /min.)
<b>Max. spindle rpm:</b>	75 rpm
<b>Metal removal rate:</b> (in C1018 steel with a sharp tool)	0.8 in <sup>3</sup> /min. (13.1 cm <sup>3</sup> /min.)
<b>Shipping weight:</b>	248 lbs. (113 kg)
<b>Cutter:</b>	1/2" square HSS tool bit or carbide inserts
<b>Radial feed:</b>	
<b>Automatic,</b>	.003" (.076mm) per revolution with handcrank
<b>Manual,</b>	up to .025" (up to .63 mm) per revolution.
<b>Axial feed:</b>	standard machine feed is manual. Optional threading attachment is adjustable in .001" (.025 mm) increments.

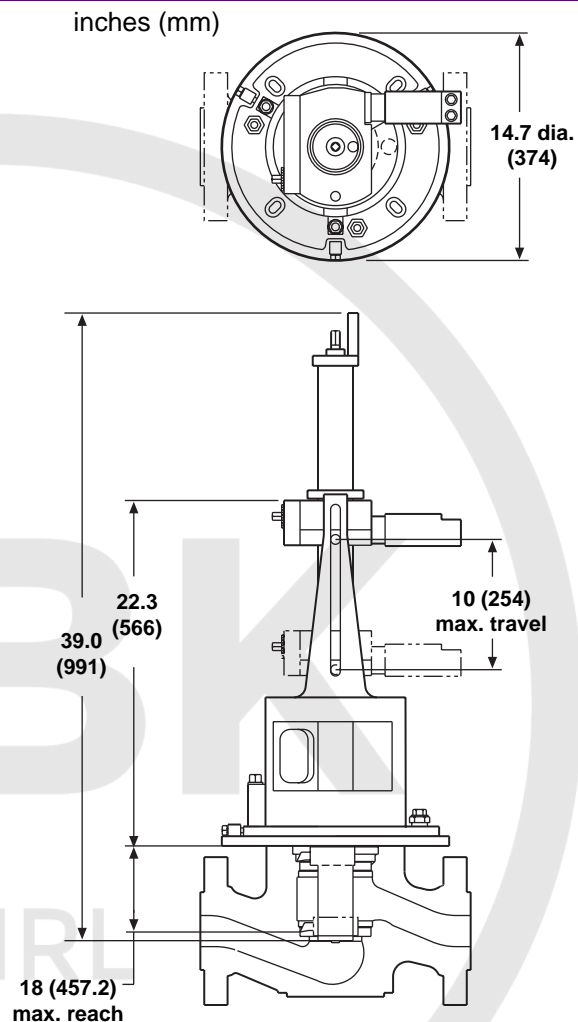

QUIK-TECH	VM7000	VM6000	VM8000	VM9000
Valve nozzle dia.	1.5-6 (38-152)	NA	NA	NA
Valve throat dia.	NA	2.5-13 (63-330)	3-10 (76-254)	16-28 (406-710)
Valve seat dia.	NA	2.5-13 (63-330)	2.5-10 (63-254)	16-28 (406-710)
Power	P	P	P, H	H

Power key: E = electric; P = pneumatic; H = hydraulic inches (mm)



## CLIMAX

Portable Machine Tools, Inc.

2712 E. Second St., P.O. Box 1210  
Newberg, Oregon 97132-8210 U.S.A.

Worldwide Tel. 503/538-2185

FAX 503/538-7600

**Call toll free 800/333-8311**

**Visit our web site:**

**[www.cpmt.com](http://www.cpmt.com)**

EIRL

447-3377

[oficina@vendo.com.pe](mailto:oficina@vendo.com.pe)