

Gate Valve Seat Grinder

Product Information

CLIMAX
Portable Machine Tools

Model VM1000

DN 32-500 (1.5-20")

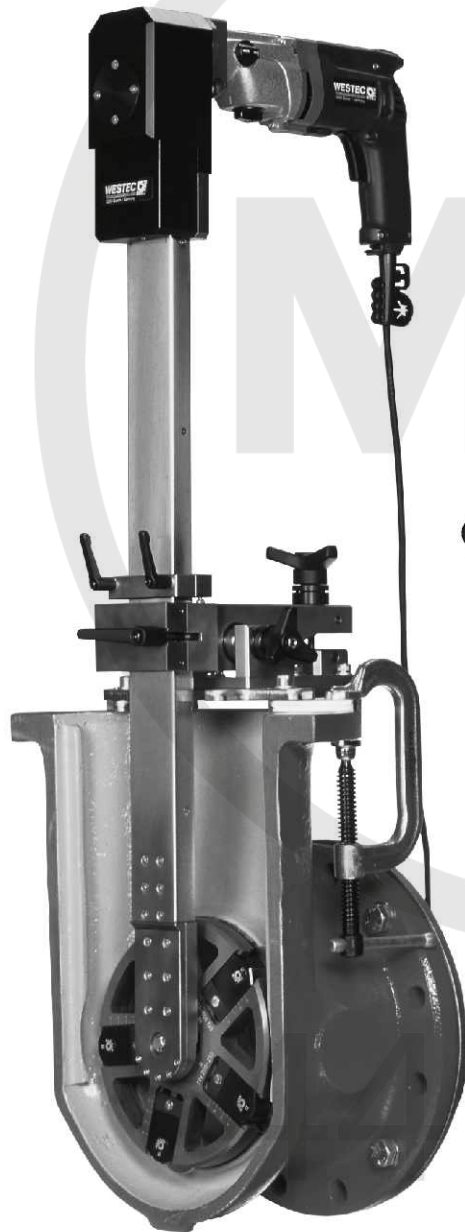

Pneumatic drive



Tilting adapter

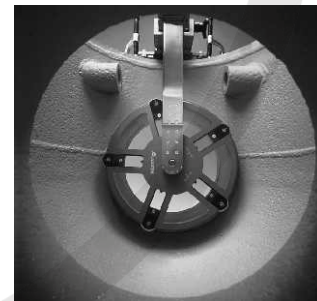

Check valve seat grinding



VISIT OUR WEB SITE
www.cpmt.com

oficina@ve...m.be

Gate Valve Seat Grinder

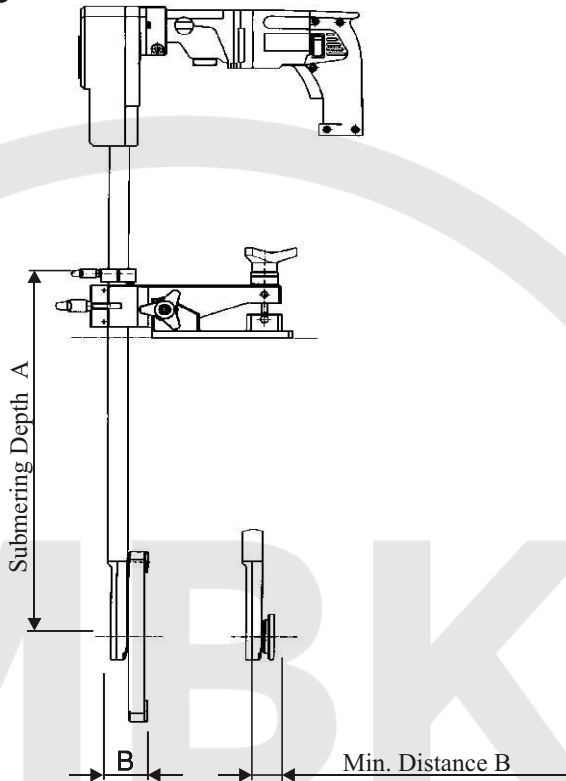

Technical Data

Model VM1000

Working range mm (inch)

min 32 (1.5)
max 150 (6)

Submerging depth mm (inch)

standard 350 (14)
optional n/a

Applications

grinding x
lapping x
CBN grinding x

Minimum B mm (inch)

flat grinding disc 30 (1.2)
planetary disc 45 (1.8)

Speed range rpm

min/max electric 100/550
min/max air 100/640

Torque N-m(ft-lb)

permanent 7 (5)
maximum 40 (29.6)

Basic machine weight lbs (kg)

6 (13.2)

#1
mm (inch)

32 (1.5)
150 (6)

350 (14)
n/a

x
x
x

30 (1.2)
45 (1.8)

100/550
100/640

7 (5)
40 (29.6)

6 (13.2)

#2
mm (inch)

40 (1.5)
350 (14)

600 (24)
800 (31)

x
x
x

35 (1.4)
51 (2)

30/500
30/400

26 (19)
108 (80.0)

10 (22)

#3
mm (inch)

80 (3)
500 (20)

800 (31)
1000 (38)

x
x
x

n/a
51 (2)

30/500
30/400

26 (19)
108 (79.9)

12 (26.4)

Company address:
Climax Portable Machine Tools, Inc.
2712 E. Second St.
Newberg, OR 97132

Phone: 503/538-2185
Fax: 503/538-7600
www.cpmt.com

CLIMAX

Portable Machine Tools

06/00, Lit Code: VGM1